

LAB 19. WAVE OPTICS: POLARIZATION – MALUS'S LAW

AP PHYSICS II

Driving Question | Objective

If light is a transverse wave, in which planes are the electric and magnetic field waves? Is it possible to limit the transverse wave to be in a particular plane?

You will use our equipment to attempt to answer the driving question above.

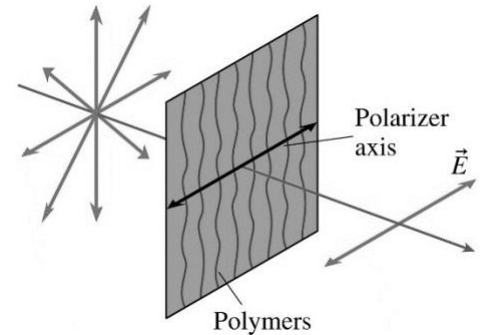

Materials and Equipment

- Light Source
- Optics Bench
- Red Diode Laser
- Rotary Motion Sensor
- Light Sensor
- Polarizer Set

Experimental Design Pt. 1 – Low Tech

1. A polarizer is a device which uses a particular lattice structure of polymers which allow only a certain orientation of an electric field to traverse through the lattice without scattering.
2. Before placing the polarizer on the bench, begin by turning on the light source and placing the viewing screen at a close enough distance to view the entire circle on the screen.
3. With one polarizer on the Polarizer Analyzer, place the polarizer and any location between the light source and screen. What happens to the intensity of the light on the screen? Why do you believe the intensity does this?

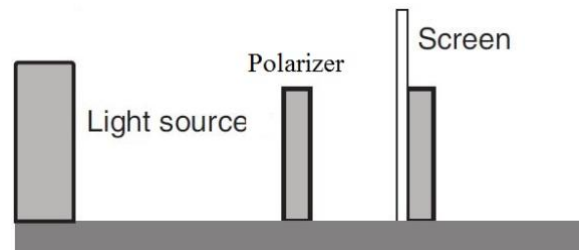

Its dimmer because not as much as light passes through

4. Place a second polarizer on the other side of the Analyzer and assure that the angles indicated on the outer edge of each polarizer are in line with the other. For example, if the 0° mark of one polarizer is at the top of the Analyzer, have the other analyzer's 0° at the top as well. This would result in the **angle difference** between the two polarizers to be 0° .
5. How does the intensity of the circle of light with 1 polarizer compare to the intensity of the 2 polarizer setup? Why do you believe this is?

The same because they are aligned the same way so they let the same amount of light pass through

6. Rotate one of the two polarizers and observe what happens to the light circle on the screen you are doing this. Is there a point in which no more light is shown on the screen? If so, at what **angle difference** does this occur?

Yes, at 90 degrees

7. What happens to circle of light as you continue to rotate one of the polarizers continuously? Feel free to take the polarizers off the bench and view a bright object across the room as you rotate one of the polarizers.

The light's intensity fluctuates from dim to bright

Experimental Design Pt. 2 – High Tech

1. Time again to use our sensors to directly graph Light Intensity vs Angle Difference between two polarizers.
2. First remove one of the polarizers from the Analyzer and place the Red Laser Diode, Polarizers, and Light Sensor as seen in the figure to the right. Note that one of the polarizers is now directly attached to a rotary motion sensor which will be recording the angular position of the second polarizer.
3. Open the DataStudio file, which will be graphing the Light Intensity of the Red Diode Laser on the y-axis and the Angular Position on the x-axis.
4. You can adjust the position of the red diode laser by adjusting the knobs on the back of the laser's stand. Assure that the laser reaches the slit located on the Light Sensor.
5. Before beginning the data collection, assure that the polarizers are in sync and press start. You will not need to turn off your monitor screen for this part of the experiment.
6. Manually adjust the angular position of the polarizer attached to the rotary motion sensor slowly in a clockwise direction. Make a couple of revolutions before stopping the data collection and observe the graph created. Insert a screenshot of your graph.

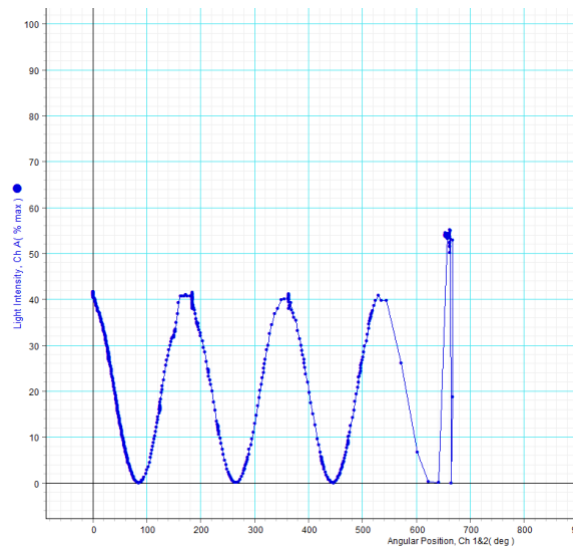
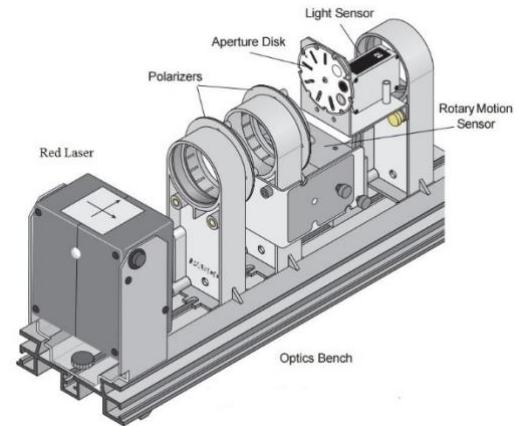

7. What kind of function does the graph seem to look like?

$\cos^2(\theta)$

8. What is the relationship between light intensity and angle difference of two polarizers?

$\cos^2(\theta)$

Analysis

1. This relationship is called Malus's Law, and claims that the transmitted light wave's intensity is proportional to the incident light intensity as well as the square cosine of the angle between the polarization axis and the plane of the incident wave. $I_{\text{transmitted}} = I_{\text{incident}} \cos^2 \theta$

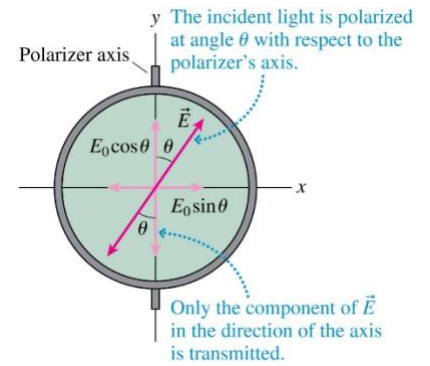
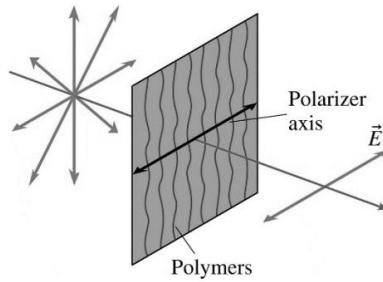

2. What happens to the intensity of unpolarized incident light after passing through one polarizer (or 2 polarizers in sync)?

It decreases in intensity

3. Unpolarized incident light strikes a polarizer with the polarizer axis in the vertical direction. That transmitted light then strikes another polarizer with the polarizer axis 20° with respect to the vertical. What is the percentage of original light intensity transmitted from the second polarizer?

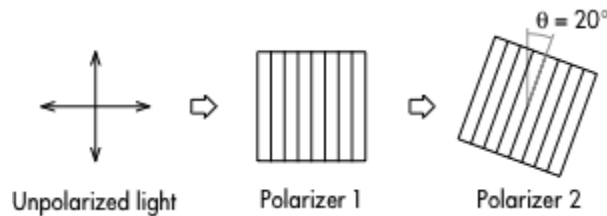

44.151 %

4. **AP MCQ Question:** Student 1 and student 2 pull on opposite ends of a horizontal string that passes through a long, thin slit in a piece of cardboard, as shown in the figure to the right. The plane of the cardboard is kept vertical, and the slit can be rotated so its angle θ relative to the dashed vertical line changes. Student 1 shakes the string, creating a transverse periodic wave that comes through the slit as a function of the angle of the slit relative to the vertical. Student 2's data is shown in the graph. In what direction is student 1 shaking the string? Highlight or color your answer.

a) **Horizontally**

b) Vertically

c) At 45° to the vertical.

d) Toward and away from the slit.

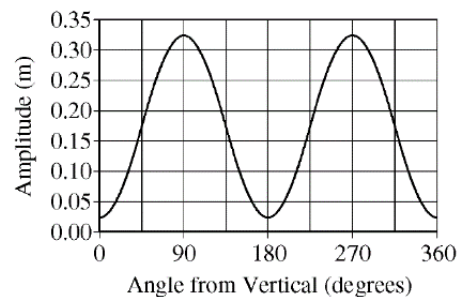
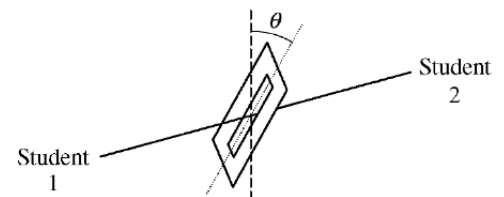

**Save this file as a PDF (NOT WORD!)
document for submission.**