

LAB 16. RAY OPTICS: HOLLOW LENS

Driving Question | Objective

Is a Convex Lens always convergent? Is a Concave Lens always divergent? What are some factors which would affect the behavior of a lens?

You will attempt to build an understanding on the connection between indices of refraction and geometric configuration of a lens in its behavior to converge or diverge light.

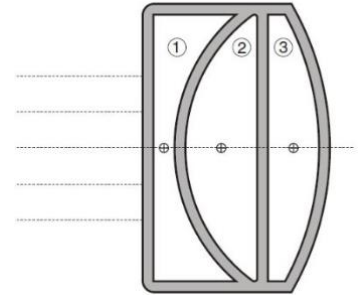

Design and Conduct Your Experiment

It is your group's responsibility to design and conduct an experiment whose data will support your answer to the driving question above. Use the answers to the pre-lab questions below to help guide your experiment design. After you have answered the pre-lab questions, write an outline of the equipment setup and procedure you will use to collect data, identifying the steps in sequence and the points at which each piece of equipment will be used.

Materials and Equipment

- Light Source (Ray Side)
- Hollow Lens
- Lens Box
- Water
- Pipette
- 150 ml Beaker

Experimental Design

1. Set the light source to output 5 parallel rays.
2. Place the light source on the left side of the box and shine the incident rays into the box. Assure that the incident rays are perpendicular to the flat side of the hollow lens.

Box

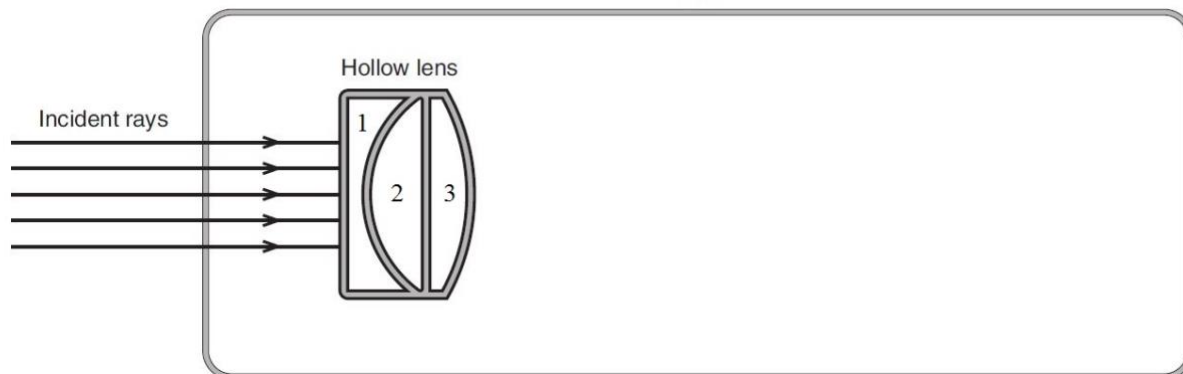

3. Is there significant refraction occurring? If so, is it convergent or divergent?

divergent

4. We will be adjusting the indices of refraction of each portion of the hollow lens in the next few steps.

- With the hollow lens in place, and the box filled with air, adjust the indices of refraction of each portion. For example, we just did 1: Air, 2: Air, 3: Air. Use the pipette to fill any combination of sections with water or air and make predictions as to whether the light will be refracted or not and whether it will be convergent or divergent.
- Once you have completed all combinations, fill the box with water and run the same trials. Does anything change?

Lens Surrounded by	Section 1	Section 2	Section 3	Prediction (Converging or Diverging)	Observation (Converging or Diverging)
Air	Air	Air	Air	Diverging	Diverging
	Water	Air	Air	Diverging	Diverging
	Water	Water	Air	None	None
	Air	Water	Air	Diverging	Converging
	Air	Water	Water	Converging	Converging
	Air	Air	Water	Converging	Converging
	Water	Air	water	Diverging	Diverging
	Water	Water	Water	Converging	Converging
Water	Air	Air	Air	Diverging	Diverging
	Water	Air	Air	Diverging	Diverging
	Water	Water	Air	Converging	Diverging
	Air	Water	Air	Converging	Converging
	Air	Water	Water	Converging	Converging
	Air	Air	Water	Converging	None
	Water	Air	water	Diverging	Diverging
	Water	Water	Water	Converging	None

- Take one trial into consideration when submerged in water. 1: Water, 2: Air, 3: Air. In this case, what is the "lens" made from
- Can a Convex Lens be divergent? Can a Concave Lens be convergent? If so, how?

Yes, if the surrounding material is more refractive than the lens

- Before you leave, please make sure that all the water is put back into your cups and that the lab station is cleaned with a paper towel if necessary.

Save this file as a PDF (NOT WORD!) document for submission.